

Namur Inductive Sensors

CYLINDRICAL HOUSING Ø 6.5 - M8-M12-M14-M18-M30
2 WIRES D.C. - VERSION-N



- ▲ **EMBEDDABLE** (FLUSH MOUNTING)
- **NOT EMBEDDABLE** (NON FLUSH MOUNTING)

TECHNICAL CHARACTERISTICS

Dimensions mm

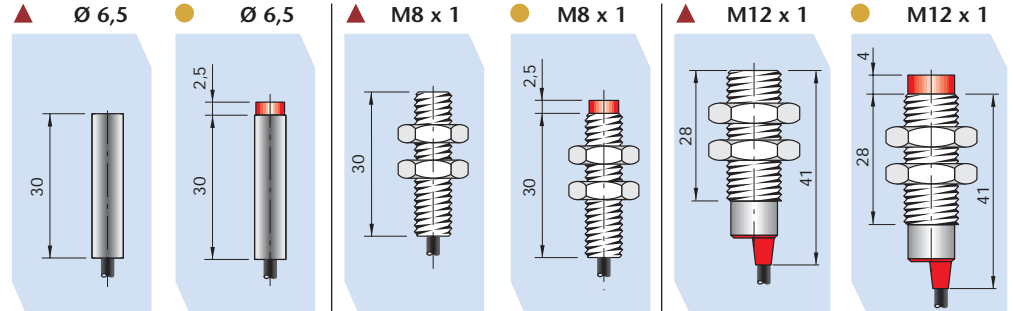

MODELS WITH CABLE

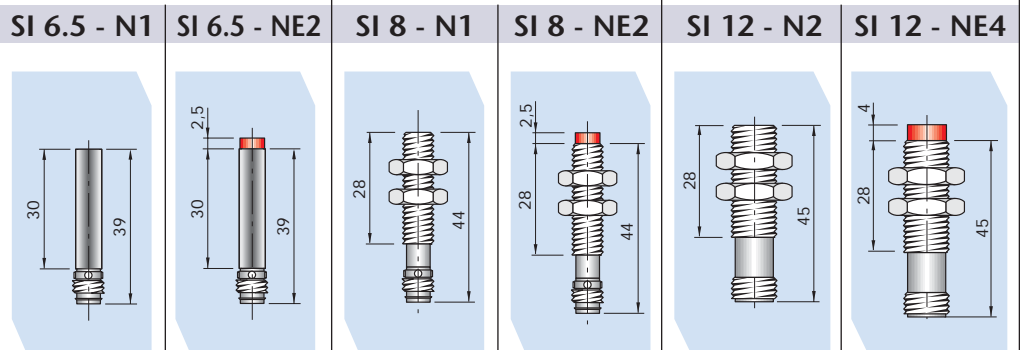

MODELS WITH CONNECTOR

| | SI 6.5 - N1 H1 | SI 6.5 - NE2 H1 | SI 8 - N1 H1 | SI 8 - NE2 H1 | SI 12 - N2 H | SI 12 - NE4 H |
|---|--|-----------------|--------------------------|---------------|--------------------------|---------------|
| Switching distance (Sn) mm | 1 | 2 | 1 | 2 | 2 | 4 |
| Continuous voltage (residual ripple ≤10%) V | 8,2 ("5 ÷ 30" see note 1) | | | | | |
| Absorption current at 8.2V mA | In presence of metal ≤ 1 mA - In absence of metal ≥ 3 mA | | | | | |
| Switching frequency Hz | 2000 | | 2000 | | 2000 | |
| Repeatability % of Sn | ≤ 3 | | | | | |
| Temperature limits °C | -25 ÷ +70 | | | | | |
| IP rating IP | 67 (With H1 - H depending on connector) | | | | | |
| Housing | Nickelled brass | | | | | |
| Cable PUR blue 2 m | 2 x 0.25 mm ² | | 2 x 0.25 mm ² | | 2 x 0.25 mm ² | |
| Connector plug | H1 | | H1 | | H | |

NAMUR DIN 19234 - EEx ia IIC T4 - NAMUR DIN 19234 - EEx ia IIC T4 - NAMUR DIN 19234 - EEx ia IIC T4 - NAMUR DIN 19234 - EEx ia IIC T4 -

WORKING PRINCIPLE

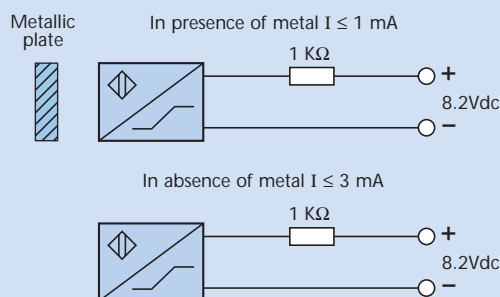
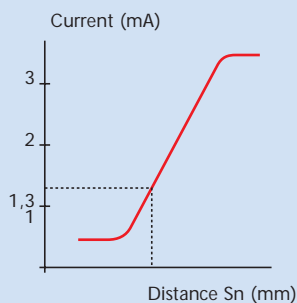



The NAMUR sensors are electronic devices whose absorbed current varies in the presence of a metallic object. The difference between these sensors and traditional sensors is the absence of amplifier trigger stages.

Note 1: In applications outside security conditions the sensors can be used in the 5-30Vdc range.

Namur Inductive Sensors

CONFORMING TO NAMUR STANDARDS (DIN 19234)
APPROVAL **EEx ia IIc T4***

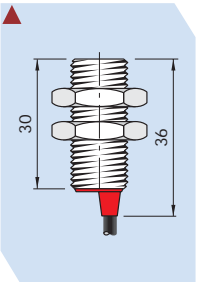
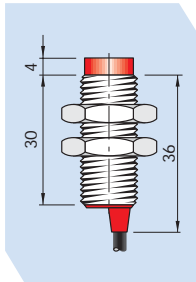
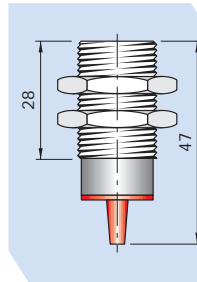
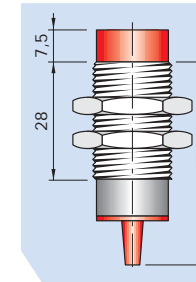
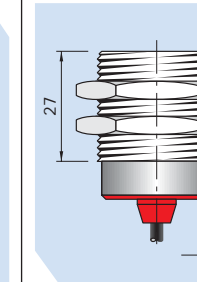
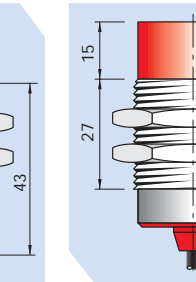

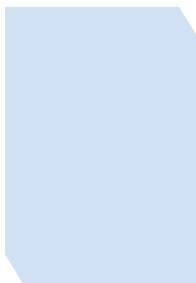
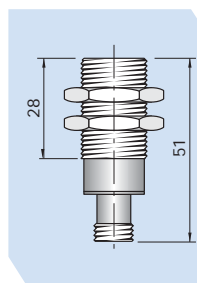
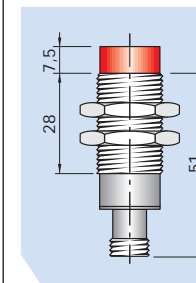
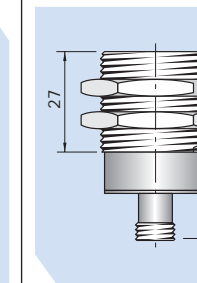
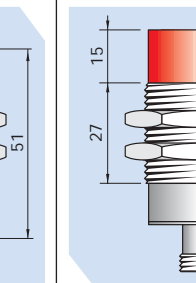
| | | | | | |
|---|--|--|--|---|--|
|  |  |  |  |  |  |
| M14 x 1 | M14 x 1 | M18 x 1 | M18 x 1 | M30 x 1.5 | M30 x 1.5 |
| SI 14 - N3 | SI 14 - NE5 | SI 18 - N5 | SI 18 - NE8 | SI 30 - N10 | SI 30 - NE15 |
|  |  |  |  |  |  |
| - | - | SI 18 - N5 H | SI 18 - NE8 H | SI 30 - N10 H | SI 30 - NE15 H |
| 3 | 5 | 5 | 8 | 10 | 15 |

8,2 ("5 ÷ 30" see note 1 at page 6)

In presence of metal ≤ 1 mA - In absence of metal ≥ 3 mA

2000

1000

500

≤ 3

-25 ÷ +70

67 (With H depending on connector)

Nickelled brass

2 x 0.25 mm²

2 x 0.50 mm²

2 x 0.50 mm²

Non previsto

H

H

- NAMUR DIN 19234 - EEx ia IIc T4 - NAMUR DIN 19234 - EEx ia IIc T4 - NAMUR DIN 19234 - EEx ia IIc T4 - NAMUR DIN 19234 - EEx ia IIc T4 -

APPLICATIONS

The NAMUR (DIN 19234) proximity switches are electronic sensors whose absorbed current varies in the presence of metallic objects.

The reduced dimensions, the low values of voltage, current and impedance (unaffected by overvoltage and excessive current from inductive or capacitive sources), allows them to be used in various applications in both intrinsically safe and normal areas.

Applications in intrinsically safe areas (explosive atmospheres). *

The sensor must be used with an intrinsically safe relay or an equivalent static input suitable for intrinsically safe applications.

Standard applications (normal atmospheres).

The sensor must be used with the supply and amplifier units ALNC, ALN2 or similar.

* When ordering, add "Ex" (Es. SI8-N1 Ex).



Namur Inductive Sensors

RECTANGULAR HOUSING SIPA8 - SIPC8 - SIP10 - SIP12 - SIP17 - SIP40 - SIQ80
2 WIRES D.C. - VERSION-N



- ▲ **EMBEDDABLE** (FLUSH MOUNTING)
- **NOT EMBEDDABLE** (NON FLUSH MOUNTING)

TECHNICAL CHARACTERISTICS

Dimensions mm

MODELS WITH CABLE

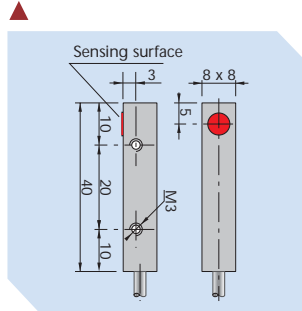

SIP A8 - N1.5

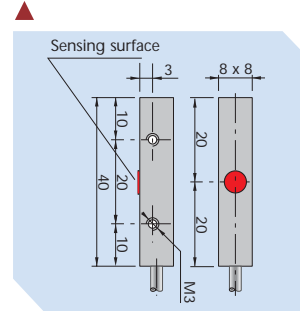

SIP C8 - N1.5

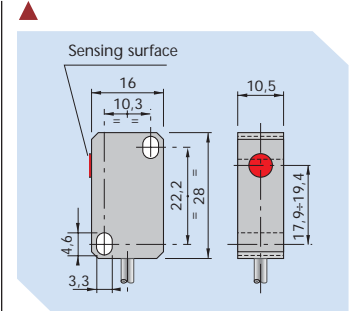

SIP 10 - N2

MODELS WITH CONNECTOR

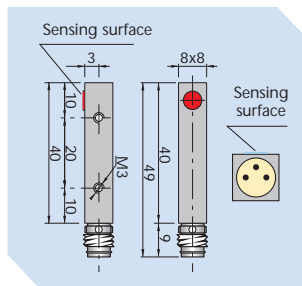

SIP A8 - N1.5 H1

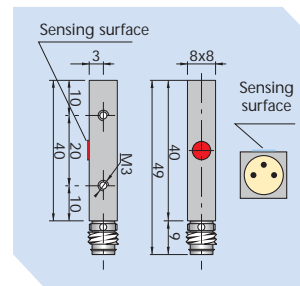

SIP C8 - N1.5 H1

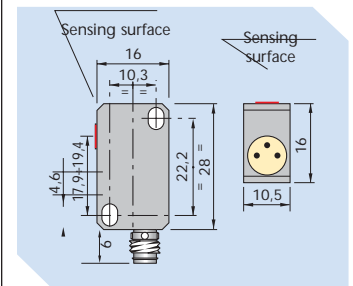

SIP 10 - N2 H1

| | | | | |
|---|---------|--|--------------------------|--------------------------|
| Switching distance (Sn) | mm | 1.5 | 1.5 | 2 |
| Continuous voltage (residual ripple ≤10%) | V | 8,2 ("5 ÷ 30" see note 1 at page 6) | | |
| Absorption current at 8.2V | mA | In presence of metal ≤ 1 mA - In absence of metal ≥ 3 mA | | |
| Switching frequency | Hz | 2000 | 2000 | 1000 |
| Repeatability | % of Sn | ≤ 3 | | |
| Temperature limits | °C | -25 ÷ +70 | | |
| IP rating | IP | 67 (With H1 depending on connector) | | |
| Housing | | Anodized aluminium | | Plastic |
| Cable PUR blue | 2 m | 2 x 0.25 mm ² | 2 x 0.25 mm ² | 2 x 0.25 mm ² |
| Connector plug | | H1 | H1 | H1 |

NAMUR DIN 19234 - EEx ia IIc T4 - NAMUR DIN 19234 - EEx ia IIc T4 - NAMUR DIN 19234 - EEx ia IIc T4 - NAMUR DIN 19234 - EEx ia IIc T4 -

WIRING DIAGRAMS WITH CABLE OR TERMINAL BLOCK

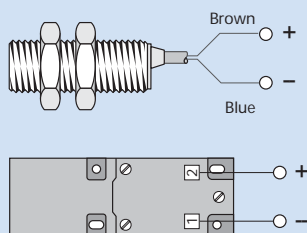

N.B.: Upon request cable for sensors with different lengths 3.5 - 5 - 7.5 - 10 metres is available.

CONNECTION WITH H1 - H - K PLUG FOR THE CONNECTORS SEE PAGE 85

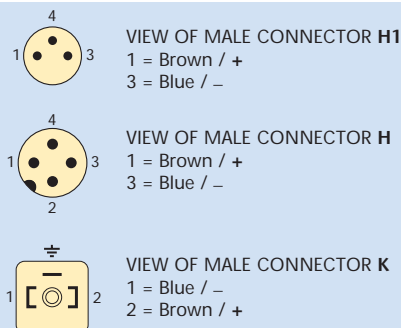

ADJUSTABLE SENSITIVITY SIP 40

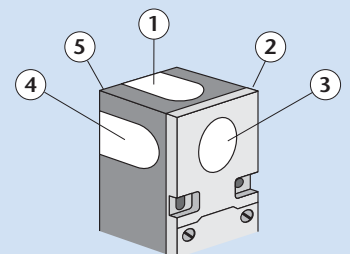

NOTE: In the SIP 40 sensor the oscillator is contained in a module which clips into the body whose surface can then be sensitive on five different positions. The surface chosen can be identified by applying the circular adhesive label.

Namur Inductive Sensors

CONFORMING TO NAMUR STANDARDS (DIN 19234)
APPROVAL **EEx ia IIC T4***

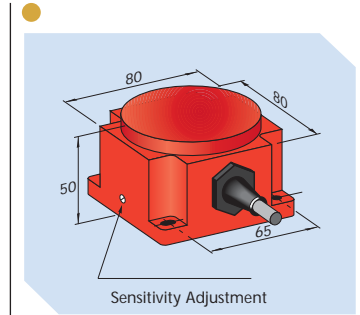
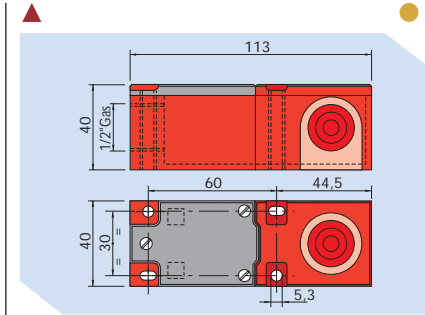
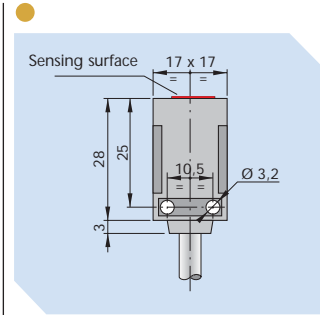
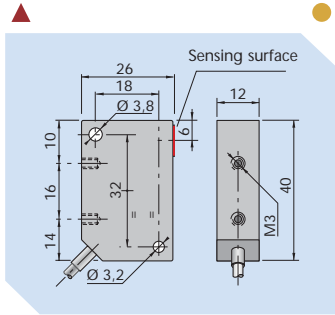

SIP 12 - N2 | SIP 12 - NE4

SIP 17 - NE5

SIP 40 - N15 | SIP 40 - NE20

SIQ 80 - NE50

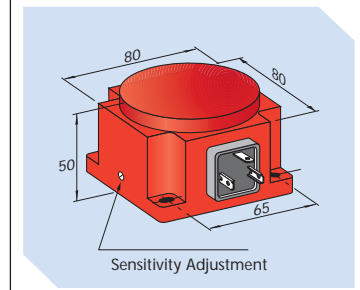
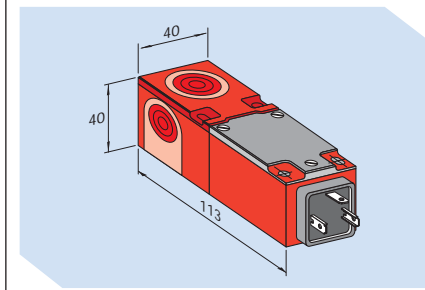
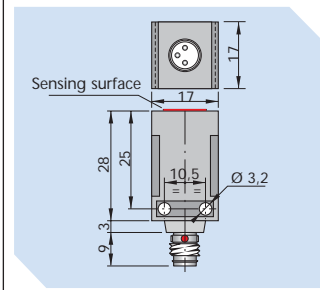
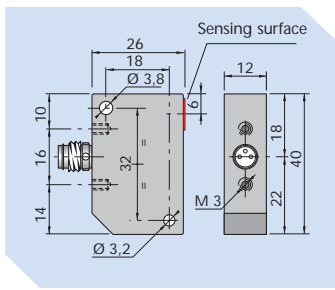

SIP 12 - N2 H1 | SIP 12 - NE4 H1

SIP 17 - NE5 H1

SIP 40 - N15 K | SIP 40 - NE20 K

SIQ 80 - NE50 K

2 | 4

5

15 | 20

10 ÷ 60 (Adjustable)

8,2 ("5 ÷ 30" see note 1 at page 6)

In presence of metal ≤ 1 mA - In absence of metal ≥ 3 mA

2000

2000

500

100

≤ 3

-25 ÷ +70

67 (With H1 depending on connector)

65 (IP67 with cable)

Plastic

2 x 0.25 mm²

2 x 0.25 mm²

Terminal block (On request cable)

2 x 0.50 mm²

H1

H1

K

K

- NAMUR DIN 19234 - EEx ia IIC T4 - NAMUR DIN 19234 - EEx ia IIC T4 - NAMUR DIN 19234 - EEx ia IIC T4 - NAMUR DIN 19234 - EEx ia IIC T4 -

SENSITIVITY ADJUSTMENT

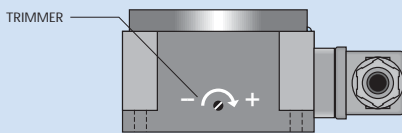

This sensor is supplied with a trimmer for the sensitivity adjustment. The sensitivity increases when the trimmer is rotated in the clockwise direction and de-creases in the anti-clockwise direction. Avoid using for a capacity greater than 60 mm referred to a square piece of (FE 37) steel of 1 mm thickness the side of which is equal to 100 mm. When setting the sensor keep in consideration all other metallic objects nearby, in fact setting is suggested to be made when the sensor is installed in the normal working conditions. The sensor is supplied already pre-set to 50 mm sensitivity.

INSTRUCTIONS FOR CORRECT INSTALLATION

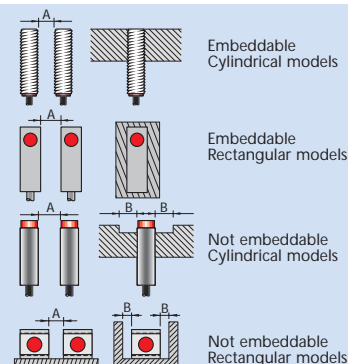

| | ▲ mm | ● mm | ● mm |
|--------|------|-------|------|
| SI 6.5 | ≥ 4 | ≥ 16 | ≥ 8 |
| SI 8 | ≥ 4 | ≥ 16 | ≥ 8 |
| SI 12 | ≥ 6 | ≥ 24 | ≥ 12 |
| SI 14 | ≥ 7 | ≥ 28 | ≥ 14 |
| SI 18 | ≥ 9 | ≥ 36 | ≥ 18 |
| SI 30 | ≥ 15 | ≥ 60 | ≥ 30 |
| SIP A8 | ≥ 2 | - | - |
| SIP C8 | ≥ 2 | - | - |
| SIP 10 | ≥ 10 | - | ≥ 0 |
| SIP 12 | ≥ 6 | ≥ 12 | ≥ 6 |
| SIP 17 | - | ≥ 20 | ≥ 6 |
| SIP 40 | ≥ 30 | ≥ 50 | ≥ 15 |
| SIQ 80 | - | ≥ 450 | ≥ 70 |

N.B. A = Mutual interference - B = Interference with metallic part

* See page 7 - Applications

ACCULEX

• 1-888-472-6676 • Fax 1-888-210-0119 • acculex.com